



18 Morin Street, P.O. Box 519
Biddeford, Maine 04005
Tel. 207.283.3001 Fax 207.283.3023
www.eaminc.com



18 Morin Street, P.O. Box 519
Biddeford, Maine 04005
Tel 207.283.0115
www.prescottmetal.com

December 6, 2022

Quote #251851

Rob Hodgson
Pro-Motion Industries

Dear Rob,

Listed below is a proposal and detailed information for the:

EAM *MINI-ST* DELTA Source Tag Applicator

The EAM *MINI – ST DELTA* Applicator is designed to apply a variety of tags such as but not limited to RF labels, Graphic labels, Coupon booklets, and RFID labels at up to 400 parts per minute. With change parts, the Delta can also apply AM tags at up to 550 ppm. Our new Delta design incorporates a more sophisticated “Micro-Stepper” drive system for greater speeds and accuracy. The *MINI-ST* Delta can accommodate web widths up to 3.5” (88mm) standard, with 4.5” (114mm) and 5.5” (139mm) options available.

These machines were developed to provide a simpler, less expensive and more accurate way to apply Source Tags. The *MINI- ST* with its small size and low price tag, this equipment opens up many more options for those who would like to add source tagging to existing production or packaging lines.

Please review the following information at your convenience. We look forward to discussing the details of this quote with you soon.

Best regards,

Steve Polley
EAM



MINI-ST Family

GENERAL DESCRIPTION

EAM offers a line of Antitheft Tag applicators for application of acousto-magnetic, RF Auto Apply labels as well as regular adhesive labels. The family name of “***MINI-ST***” aptly describes these units due to their small size and price tag as well as simplicity. As a result of EAM’s early involvement in the use of off-the-shelf label applicators for AM tag application, initial design criteria for

the ***MINI-ST*** revolved around minimizing its size (or footprint). In some cases such as the AM tag, EAM supplies the Delta with dedicated tooling thus minimizing the need for lengthy adjustments on the production line. For other applications such as standard adhesive labels, the tooling (tamp head assembly) provides adjustment for various label sizes.

Also offered is EAM’s new Multi-Head Controller. This unit automatically switches applicators if tags run out or if there is an error, and is also capable of custom pattern tag application. This can provide true continuous operation.

Family of *MINI-ST* Applicators

***MINI-ST 300* (Intermittent motion applications only.)**

Rates up to 250 PPM (15,000 per hour)

- Used for the application of Acousto-Magnetic Tags (AM) ***.

***MINI-ST FG24-2* (suitable for continuous motion applications)**

Rates up to 400 PPM (24,000 per hour)

- Used for the application of Acousto-Magnetic Tags (AM) ***.

MINI-ST DELTA

Can be used to apply a wide range of adhesive labels

Rates up to 550 PPM (30,000 per hour)

- RF labels
- Graphic labels
- Coupon booklet labels
- RFID Tags
- AM Tags

Plus others (please contact us to discuss your project)

| Part Number | Description | Price | Quantity | Price Total |
|-------------|---|-------------|-----------------|--------------------|
| DL5830 | Mini ST Delta Labeler with Controls Enclosure and a single Powered Unwind (Includes Label Head) | \$19,380.56 | 1 | \$19,380.56 |
| DL5830-01 | Pivot/Tilt Mount (Stand Style) | \$731.58 | 1 | \$731.58 |
| DL5830-26 | Spare Parts Kit | \$2,083.33 | 1 | \$2,083.33 |
| DL5830-19-L | Encoder (Linear Mounting) | \$1,772.35 | 1 | \$1,772.35 |
| DL5830-11 | Single Stand with Horizontal Adjust | \$3,322.50 | 1 | \$3,322.50 |
| DL5830-08 | Trigger Sensor | \$445.25 | 1 | \$445.25 |
| | | | SubTotal | \$27,735.57 |
| | Distributor Discount | 20 | % | -\$5,547.11 |
| | | | Total | \$22,188.46 |

See next page for Shipping, Installation/Training cost detail

The Delta labeler is to be configured as follows:

- Left Hand or Right Hand
- Adjustable Label Head or AM Tag Head
- 20- 60mm Tamp Cylinder Stroke (dependent on application requirements)

We have many other options available, and solutions for most any application requirement, including:

- Oversized label heads and custom tamp assemblies for large or specialty labels.
- Additional powered reel unwinds and manual splice blocks for quicker reel changes.
- Low product detect/alert for product reels.
- Control signal isolation for interfacing with host automation.
- Multi applicator systems for complex patterning of different tag types, same tag type redundancy or same tag type increased thru put.

Please call to see how we can help.

Shipping:

\$TBD

EX WORKS, EAM INC. BIDDEFORD, MAINE, USA

Applicator only: Ups shipment approx. 100#

Applicator and Stand: 40X48 pallet truck shipment approx. 350#

Quotation valid for 30 days

Note:

EAM is continuously engaged in R&D efforts to improve and evolve its products and designs. All specifications are subject to change without notice.

Start-Up & Training

A service technician can be provided at EAM’s standard service rates.

Estimated Costs:

| | |
|--|--------|
| Round trip flight | \$xxx |
| Hotel x nights | \$xxx |
| Per-diem x days | \$xxx |
| Travel (\$500/day) x days | \$xxx |
| Installation/Training (\$1150/day) x days | \$xxxx |
| Total | \$xxxx |
| | |

Travel & expenses will be billed at actual cost.

Includes: airfare, hotel, rental car, meals, parking, and tolls.

Terms:

50% with Purchase Order 50% Prior to Ship

Conditions:

Orders are accepted and acknowledged only under EAM Standard Terms and Conditions attached.

Delivery:

2-3 weeks after receipt of **down payment** and order. Due to varying workloads, actual delivery to be confirmed at time of order.

Please address all payments to:

EAM, Inc
18 Morin Street
PO Box 519
Biddeford, ME 04005
Attn. Accounts Payable





EAM MINI ST DELTA LABELER MOUNTING EXAMPLES

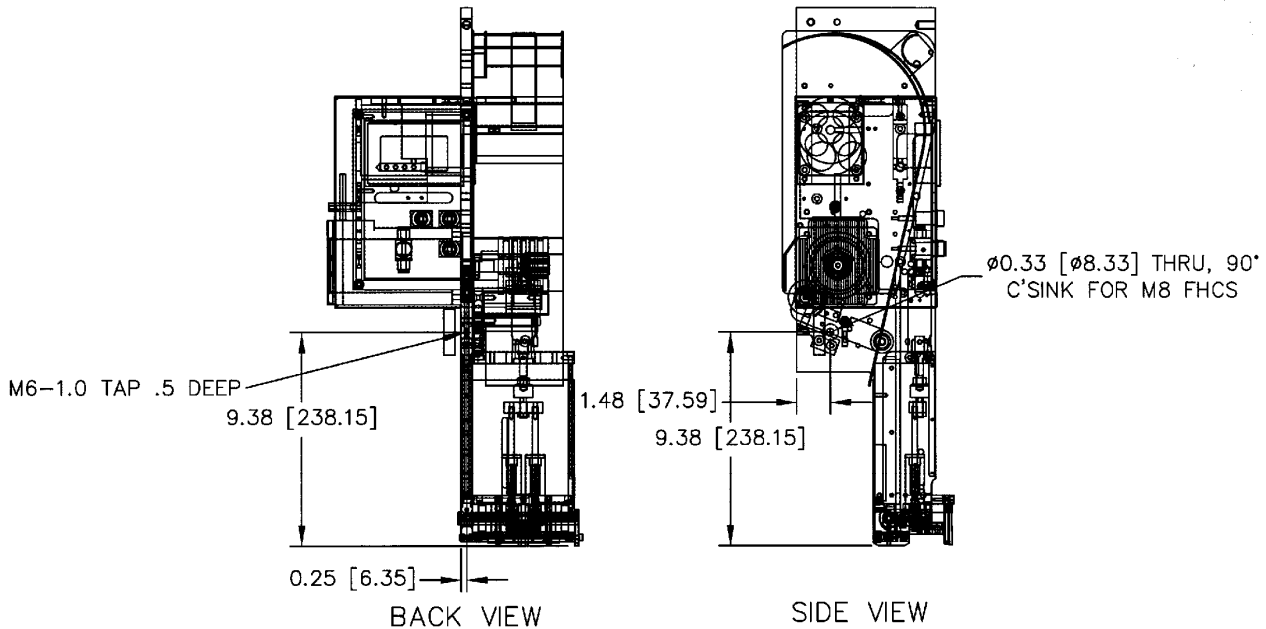
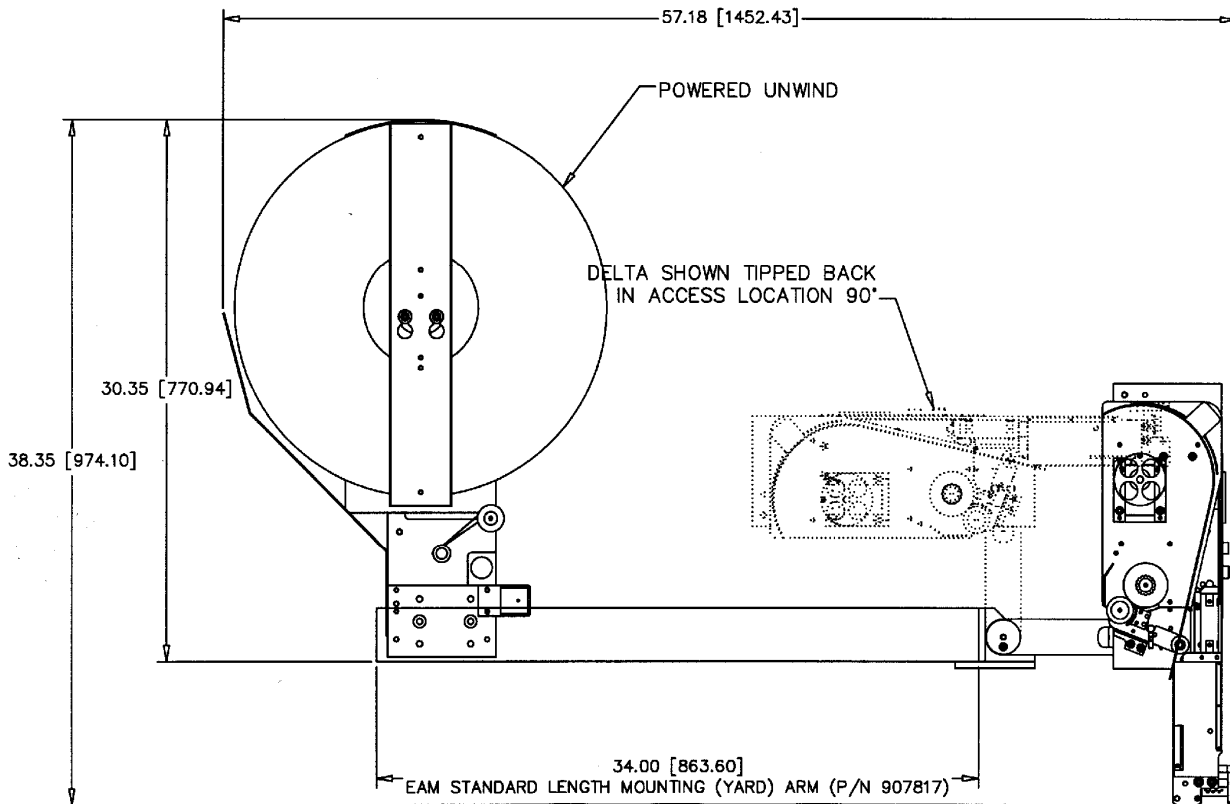

LH APPLICATOR SHOWN

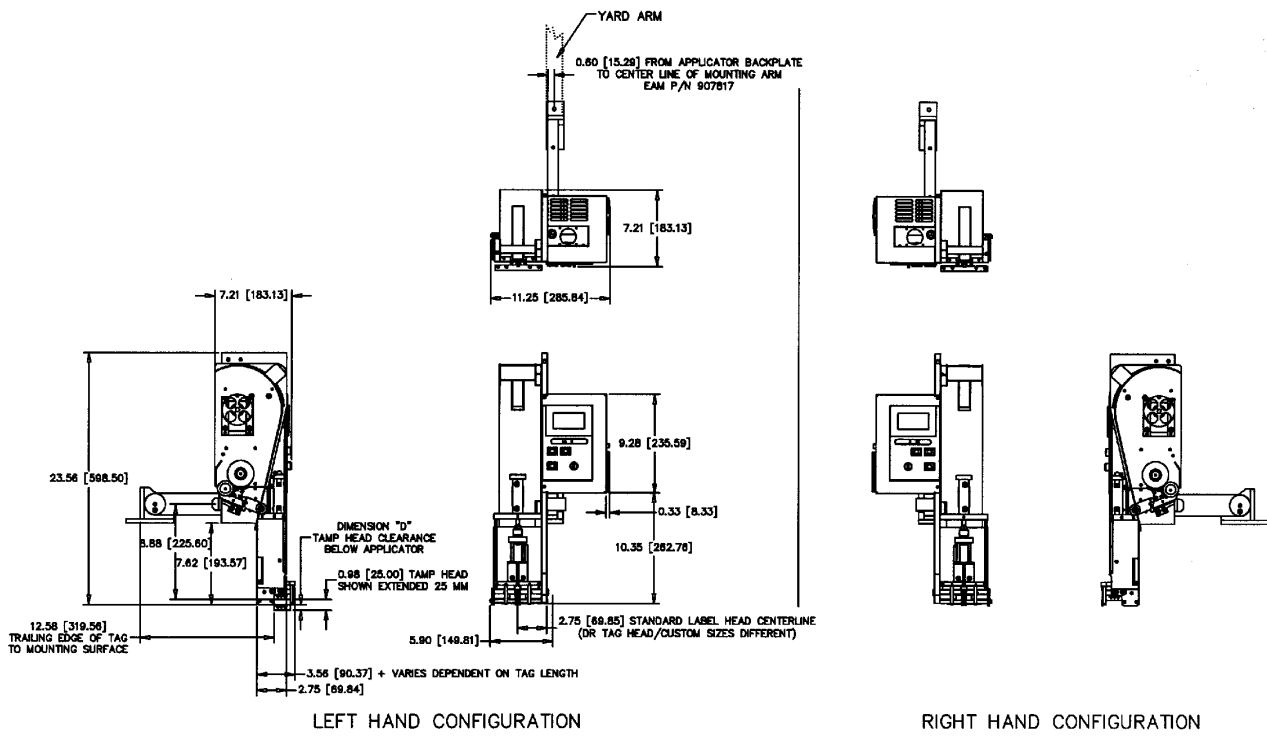

ELECTRICAL PANEL DETAIL

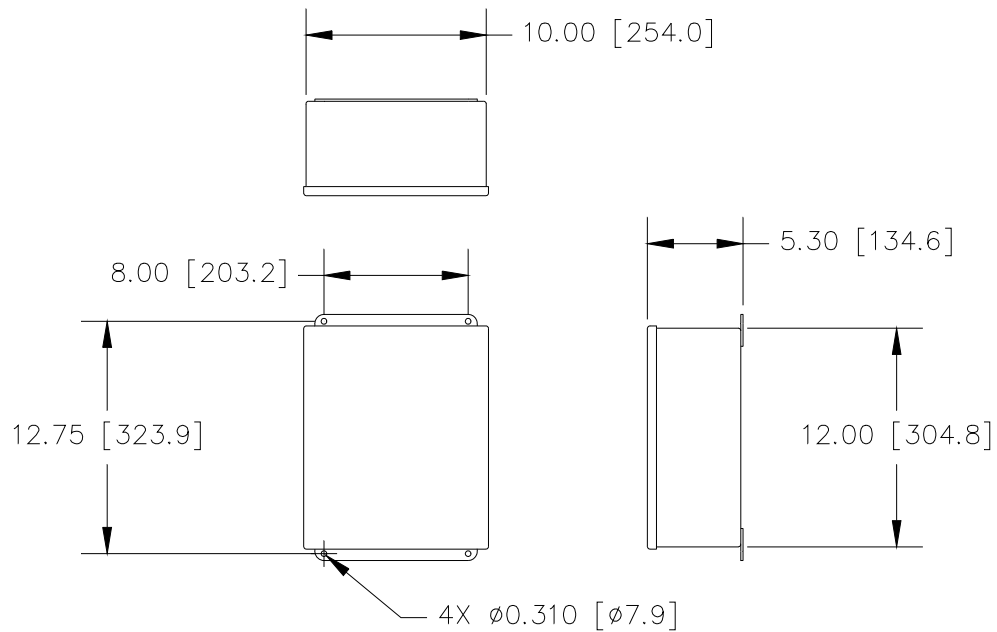

Standard Service Requirements:

110 VAC, Single Ø, < 3 Amp
85 PSI, < 2CFM

High Voltage Service Requirements:

Several voltages available.
To be determined based on customer requirements.

Machine Dimensions:

450MM X 193MM X 250MM

17.8" (h) X 7.6"(W) X9.9" (D)

Remote Mounted Electrical Enclosure Dimensions:

10"X12"X6"

Weight:

Approximately 35 lbs. Dependent upon options.

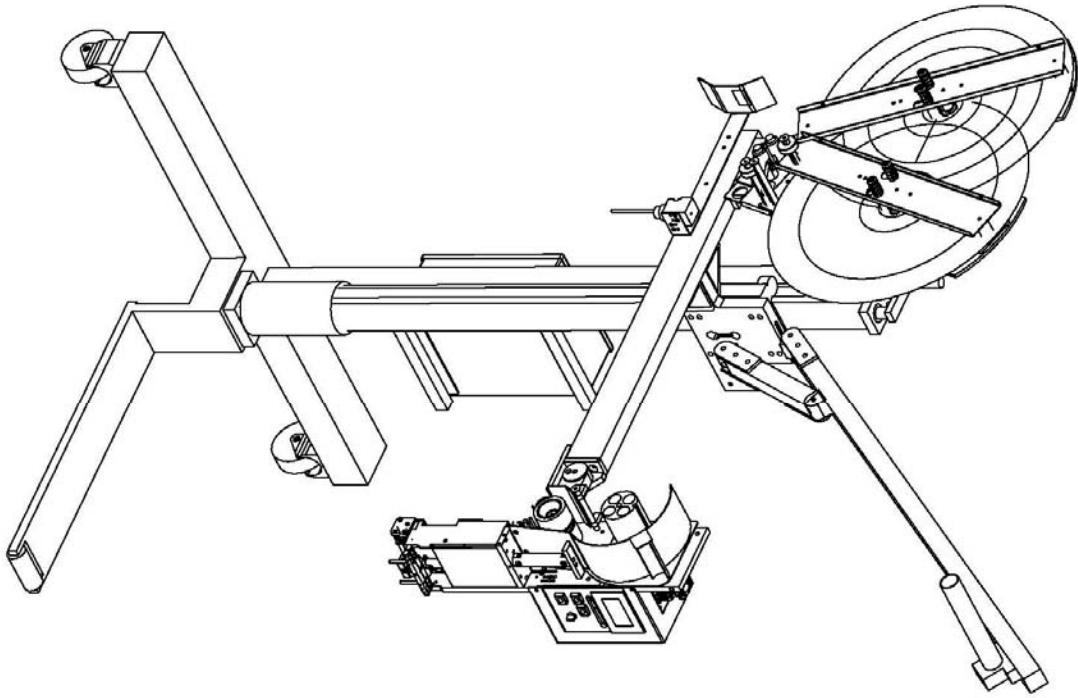

EAM LABELER STAND
VIEW: ISOMETRIC

THIS LAYOUT REPRESENTS
DELTA HIGH SPEED UNWIND

THIS LAYOUT REPRESENTS
LOW TOE STAND (OTHER
STAND CONFIGURATIONS AVAIL.)

THIS LAYOUT REPRESENTS LH DELTA
CONFIGURATION. RH UNIT WOULD BE A
MIRROR IMAGE OF THIS LAYOUT,
INCLUDING POWERED UNWIND. STAND AND
OVERHEAD BOOM REMAIN THE SAME.

EAM - Engineered Automation of Maine, Inc.

GENERAL TERMS AND CONDITIONS OF SALE

Prices

Prices are subject to change without notice at any time prior to acceptance of Buyer's order by Seller.

Prices are net EX-WORKS EAM's facility except as noted, and are quoted with the express understanding that any and all federal, state, local or foreign sales, use, consumption, excise or other taxes levied, or which may be levied by any taxing authorities, will be paid by Buyer, or in lieu thereof Buyer shall provide Seller with a tax-exemption certificate acceptable to the taxing authorities.

Delivery

Estimate of delivery starts from the date complete details and specifications necessary to permit the start of design and manufacture are received and accepted by Seller.

Buyer acknowledges that Seller shall not be liable for damages for any contingency beyond Seller's control including, but not limited to, delays caused by strikes, acts of God, accidents, scarcity of materials, or delay in transportation.

If, upon notification from Seller that the Product is ready for shipment, Buyer requests Seller to delay such shipment, Buyer shall pay Seller the reasonable cost of the storage of same until shipment is made pursuant to Buyer's instructions. Payment of storage charges does not waive payment provisions specified under Payment below.

Shipment of Product is conditioned upon full compliance by Buyer with all terms and conditions except such as may be expressly waived in writing by Seller. Any such waiver, however, shall not be construed as a waiver of any other right of seller.

Risk of Loss

Product shipped is not insured unless so ordered. All risk of loss, injury or destruction of Product shall be borne by the Buyer (1) upon delivery thereof by Seller to any carrier for shipment to Buyer, or (2) in the event and from the time shipment of Product is delayed pursuant to instruction from the Buyer for any reason whatsoever. Any such loss, injury or destruction shall not release Buyer from its obligation to pay the purchase price therefore.

EAM Limited Warranty

The Seller warrants to the Buyer that Product shall be free from defects in material and workmanship for a period of twelve (12) months from the earlier of the date of shipment, or the date that Buyer delays shipment for any reason whatsoever.

All labor costs incurred by Buyer, either for normal maintenance or repairs including parts covered under warranty are the responsibility of the Buyer. Any on site labor costs incurred by Seller for warranty repairs are the responsibility of the Buyer.

Seller shall be liable for the repair or replacement (at Seller's sole option) of any parts that fail through defect in material or workmanship during the period of this warranty as aforesaid at its own cost and expense, provided that:

(A) Buyer shall provide Seller with written notice of, and full opportunity to investigate, the nature of the defect or failure within ten (10) days of Buyer becoming aware of the same (but in no event shall the twelve (12) month duration of the warranty be extended by reason of failure to discover the defect for any cause);

(B) The Product has been properly installed, maintained and operated in accordance with all instructions of Seller;

(C) The Product shall not have been repaired or altered in a manner not in conformity with Seller's instructions or in any way so as to, in the Seller's judgment, affect

its performance, useful life span or reliability;

(D) The Product shall not have been subjected to misuse, negligence, lack of maintenance or accident, or operated other than in strict accordance with Seller's instructions.

Seller shall under no circumstances have any liability whatever for any loss or damage either direct, indirect or consequential sustained by the Buyer by reason of the condition or suitability of the premises in or upon which the Product is to be installed and operated including, but not limited to, foundations, soil conditions, structural materials, or other structural design requiring civil engineering. In the event Buyer at anytime refuses to permit Seller or its representatives to enter Buyer's premises for the purpose of inspecting the installation, operation, maintenance and care by the Buyer of the Product, Seller's responsibility under the forgoing warranty shall immediately cease.

All of Seller's expenses of investigation of any claimed defect shall be borne by Buyer if the Product under investigation is not found to be defective.

In any case where Seller authorizes Buyer to undertake repairs, Buyer shall be entitled to reimbursement of costs incurred by the Buyer for the material purchased, at cost, and labor expended, at direct labor rates, in effecting said repairs, provided that such authorization from Seller is in writing; beyond this, Seller shall have no further liability.

The forgoing warranty does not extend in any way to tools or other parts subject to wear or which, under normal usage, have a service life inherently shorter than the twelve (12) months.

This warranty shall expire on any resale or re conveyance of the machinery or equipment by Buyer.

This warranty is the only warranty, express or implied, made by the seller in connection with the sales of machinery or equipment and is in lieu of any warranty of merchantability or fitness for a particular purpose and of all other warranties. Seller

shall under no circumstances have any liability whatsoever for loss of use of said machinery or equipment, nor shall Seller be liable for any indirect or consequential damages resulting there from.

Changes in Design and Improvements

Buyer acknowledges that the provisions in the drawings and/or specifications for the Product are descriptive only and not intended as warranties from Seller, unless expressly stated to be such.

Seller shall have the right, but not the obligation, to make changes at any time in the specifications for the Product in order to incorporate therein later developments and improvements subject, however, in the case of substantial changes, of the written approval of Buyer.

Performance of Machinery or Equipment or Any Part Thereof

Performance and productivity specifications of the Product shall be binding upon Seller only if:

(A) Such specifications originate from Seller as the manufacturer, and are specified in writing by the Seller or its authorized representative as binding upon Seller, and (B) The Product is operated only by experienced and trained personnel in an acceptable operating environment and upon material described in Buyer's specifications of intended usage.

No oral representation on performance or productivity of the Product will be recognized.

Cancellation

Buyer may, upon thirty (30) days written notice to Seller prior to Seller's completion of the subject Product, cancel such order, subject to the provisions described below.

Upon receipt of Buyer's written cancellation request, Seller will stop work as promptly as possible on said order, and in such event Buyer will pay Seller as liquidated damages arising out of such cancellation, and not as a penalty, a charge on the basis of all engineering executed relative to the order, and of order prices for all completed Product, the full cost incurred by Seller or any affiliate of Seller for uncompleted Product, plus Twenty Percent (20%) thereof, and the cost of packing and storing same.

Reserved Rights

Quotations, estimates, drawings, photos or other documents are submitted on the condition that property and copyright rights are reserved to Seller and that such data be not rendered accessible to third parties or used in any way detrimental to Seller. No Product may be built by Buyer, its successors or assigns according to Seller's drawings and specifications without first obtaining Seller's written permission.

Payment

Invoice date shall be the earlier of date of actual shipment of Product, or date Product is ready for shipment should Buyer request a delay. Payment shall be in full within thirty days from invoice date unless other payment terms are agreed upon in writing. Claims for defects or defective parts, loss or damage in transit, and claims of Buyer against Seller shall be no defense for nonpayment of any sums due on the

purchase price of Product. All sums shall become due and payable as provided herein and shall be immediately paid when due. In the event of default as defined above, the APPLICANT/business agrees to pay the maximum legal rate of interest or service charge at the rate of and not exceeding 2% per month (24% annually) on all unpaid and delinquent accounts together with all reasonable attorneys' (third party credit collection organization) fees for the collection and enforcement of all delinquent accounts together with all costs thereof.

Title

Title to Product shall not pass to Buyer until full payment has been received by Seller.

Buyer acknowledges that until payment in full has been made to Seller for Product, such property shall be and remain strictly personal property and retain its character as such, no matter whether on permanent foundation or in whatever manner affixed or attached to any building or structure, or what may be the consequences of its being disturbed on such foundation, building, or structure, or for what purpose the Product may be used.

Entire Agreement

This order and its appended price and specifications agreement(s), as accepted and approved by Seller, shall constitute the entire order from Buyer to Seller. All previous representations and agreements, either oral or written, are entirely superseded and canceled hereby.

No change in or modification of this order shall be binding on Seller unless such change of modification shall be set forth in writing, approved by Seller, and explicitly made part of this order either by attachment thereto or endorsement thereon.