

# MODEL 560S

Semi-Automatic Tamp Down Labeler

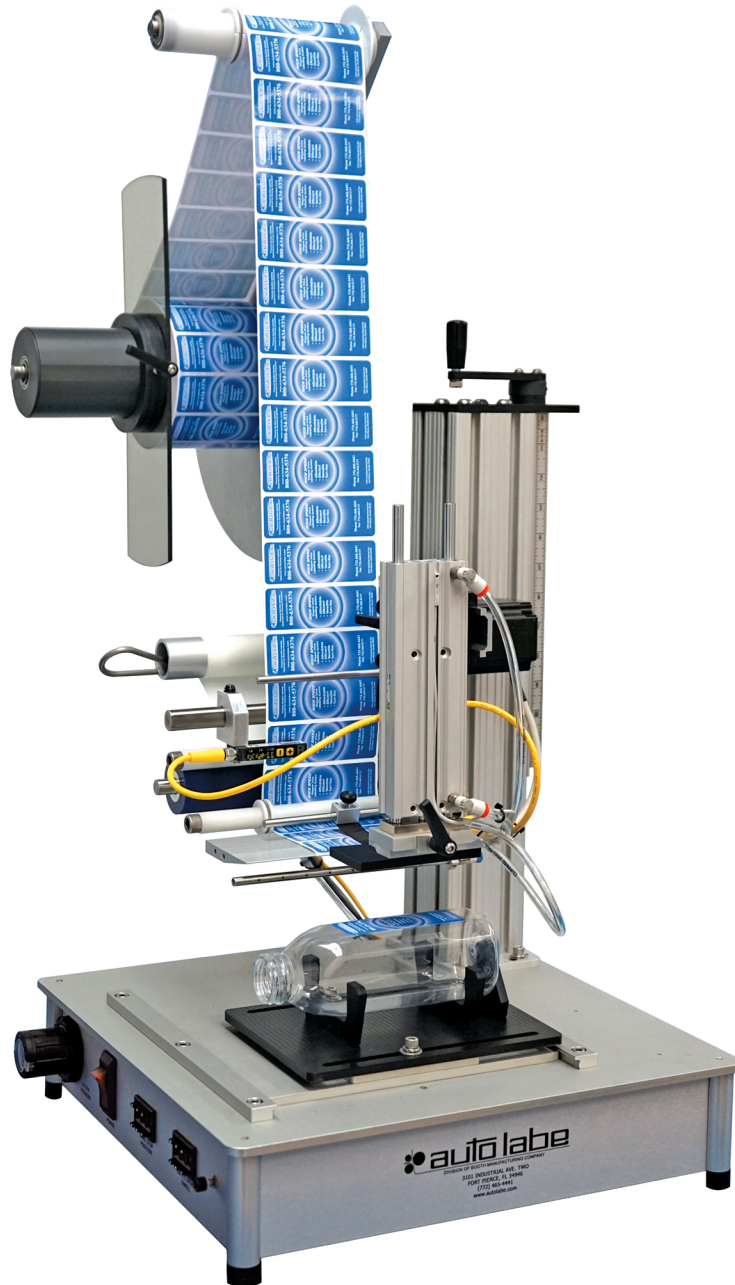

 auto labe

Division of Auto Labe Industrial, Inc. 1990  
1912 Industrial, P.O. Box 1990  
P.O. Box 1990, Ft. Lauderdale, FL 33301  
352.461.4444  
www.autolabe.com

# MODEL 560S

## Semi-Automatic Tamp Down Labeler

- Cost effective and time-saving alternative to manual labeling
- Economical for small production runs
- Includes custom tamp head and product fixture
- Portable and lightweight

### STANDARD FEATURES:

- PLC controlled
- Stepper label drive motor
- Photoelectric label sensor
- Foot switch activation
- Label dispense speed of 40ft/min
- Integrated regulator with gauge
- Easily adjustable product fixtures
- Smart label stop delay
- Label advance switch
- Accommodates various label types

### SPECIFICATIONS:

#### Weight / Dimensions (overall):

Weight: 50lbs.  
Width: 18 in. / 45.72 cm.  
Length: 25 ½ in. / 64.77 cm.

#### Shipping weight/dimensions:

55lbs. (approx.)  
30" in. cubed / 76.2 cm.

#### Electric:

110 VAC 50/60Hz / 10 AMP  
220 VAC 50/60Hz / 5 AMP

#### Air:

50PSI (min.) to 90PSI (max.)  
2CFM

### LABEL SPECIFICATIONS:

Standard 6" web width  
12" O.D. roll with 3" core  
Pressure sensitive / die cut

### OPTIONS AVAILABLE:

- Inkjet label coding
- Hot stamp imprinter
- Clear label sensor
- Extra wide label kit
- Front/back labeling
- Resettable counter
- Additional tamp heads and fixtures

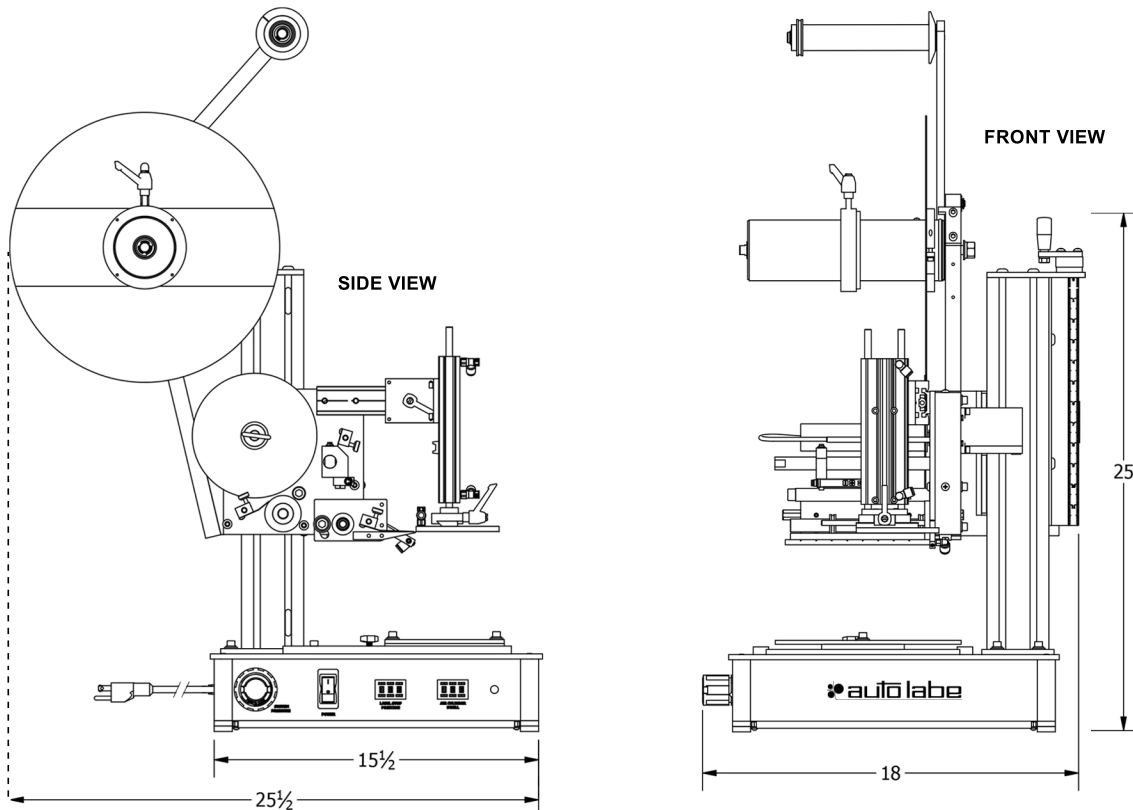

3101 Industrial Avenue Two, Fort Pierce, Florida 34946  
772-465-4441 • www.autolabe.com • e-mail: info@autolabe.com