

MODEL 155

Automatic Print & Apply Label Applicator

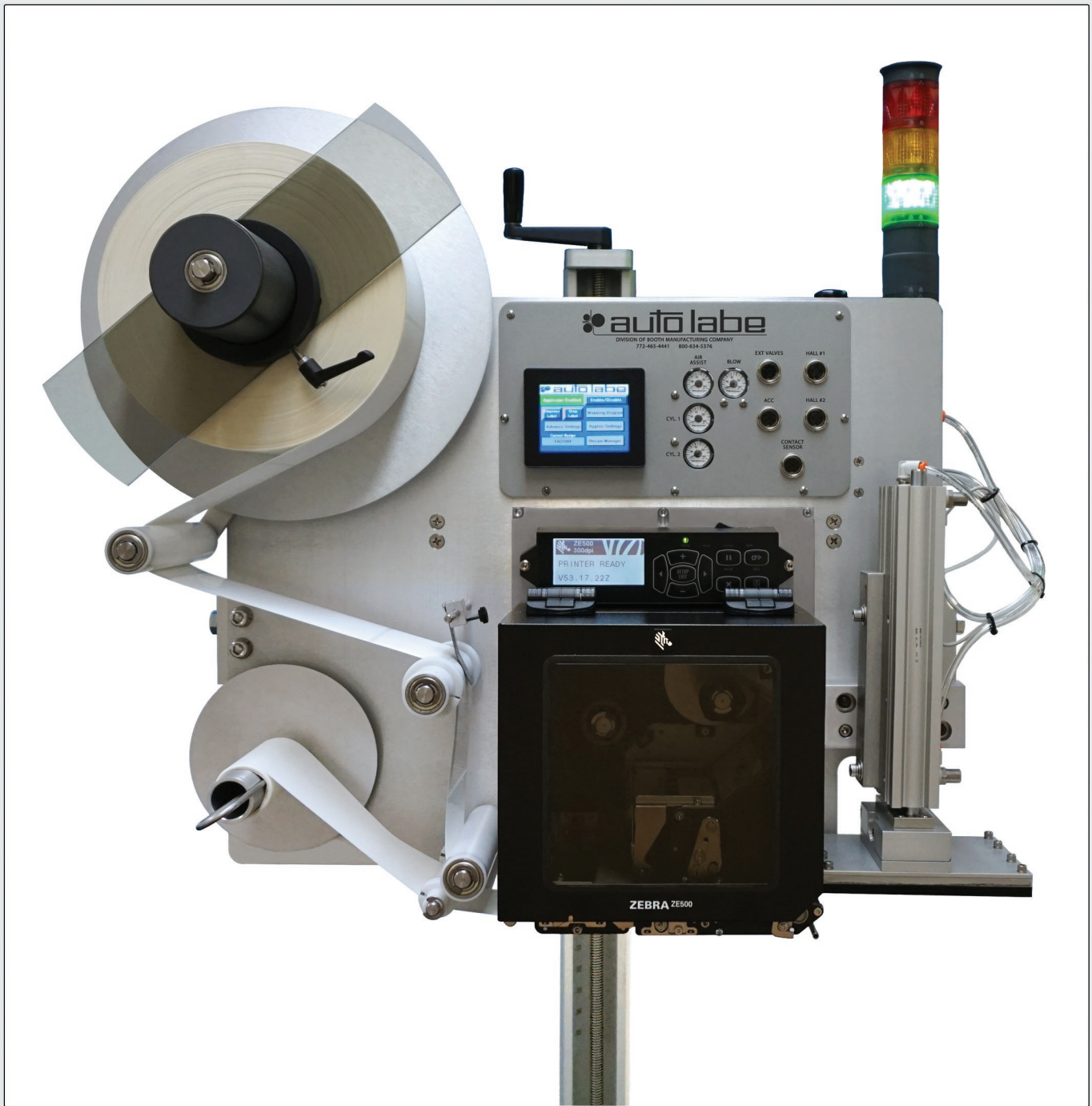

 auto labe

MODEL 155

Automatic Print & Apply Label Applicator

Auto Labe's new Model 155 Print & Apply system integrates a Tamp, Blow, Air-Tamp, or Smart Tamp label applicator with high performance thermal transfer and direct thermal printers. It also incorporates a color touchscreen and PLC for easy menu driven operation and control. No more relays or circuit board problems to worry about. Built to last with only the best components available for maximum versatility and performance.

FEATURES:

- Exceptional label placement.
- Built for industrial environments.
- Flexible mounting allows labeling from the side, top, or bottom.
- Tamp-down for recessed label application.

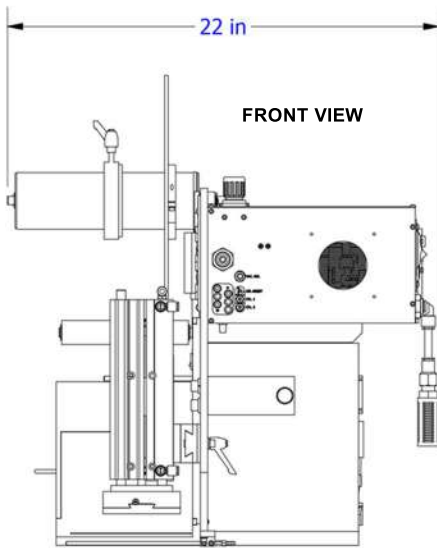

OPTIONS/ACCESSORIES:

- Tamp/Blow Labeling
- Adjacent Side Carton Labeling
- Corner Wrap Carton Labeling
- Smart Tamp Labeling
- Web Monitoring Systems
- Accumulators/Descramblers
- Heavy Duty Stands
- Custom Hardware and Mounts
- Custom Conveyors
- Software Packages
- Spare Parts

SPECIFICATIONS:

Interface:

USB, RS232, Ethernet, Parallel, and Wireless.

Air Requirements:

3 CFM @ 90 PSIG.

Electrical Requirements:

110 VAC 60Hz/5 AMP.
220 VAC 50hz/5 AMP.

Equipment Weight:

(Applicator & Print Engine)
75 lbs/36kg. (approximate)

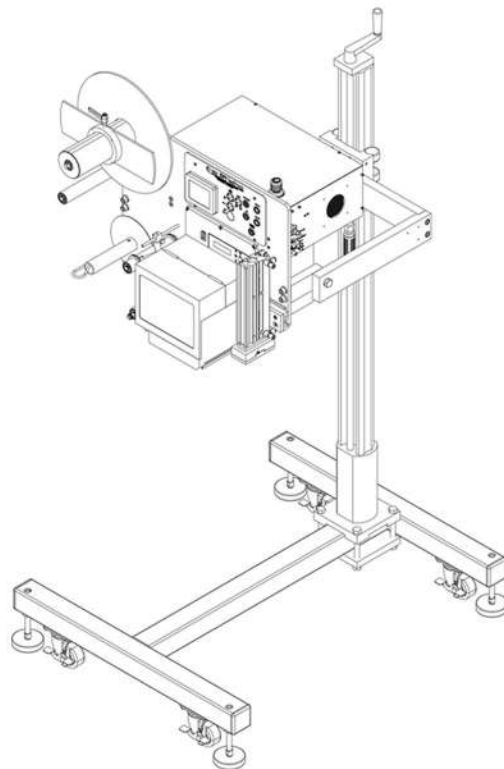

PRINT ENGINE OPTIONS:

SATO S84-ex

203 or 300 dpi
Print Speed: (up to 16"/sec or 12"/sec)
Maximum Print Width: 5"
Print Method: Thermal Transfer
Direct Thermal

SATO S86-ex

203 or 300 dpi
Print Speed: (up to 14"/sec or 12"/sec)
Maximum Print Width: 6"
Print Method: Thermal Transfer
Direct Thermal

ZEBRA ZE500-42/43

203 or 300 dpi
Print Speed: (up to 12"/sec)
Maximum Print Width: 4.1"
Print Method: Thermal Transfer
Direct Thermal

ZEBRA ZE500-62/63

203 or 300 dpi
Print Speed: (up to 12"/sec)
Maximum Print Width: 6"
Print Method: Thermal Transfer
Direct Thermal

DATAMAX A-4212/A-4310

203 or 300 dpi
Print Speed: (up to 12"/sec or 10"/sec)
Maximum Print Width: 4.094"
Print Method: Thermal transfer
Direct Thermal

DATAMAX A-6212/A6310

203 or 300 dpi
Print Speed: (up to 12"/sec or 10"/sec)
Maximum Print Width: 6.61"
Print Method: Thermal Transfer
Direct Thermal

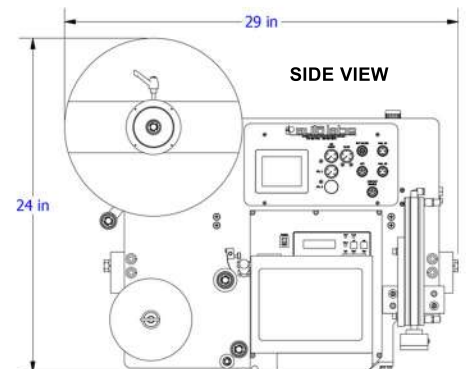

3101 Industrial Avenue Two, Fort Pierce, Florida 34946
Toll Free 800-634-5376 • 772-465-4441 • Fax 772-465-5177
www.autolabe.com • e-mail: info@autolabe.com