

MODEL 550

Semi-Automatic Round Product Labeler



 auto labe

MODEL 550

Semi-Automatic Round Product Labeler

- Very economical for small production runs.
- Cost effective transition from manual labeling to fully automatic labeling.
- Maintains consistent and high label registration.
- Accurately places labels on round products from 3/8" to 4" diameter.
- Label application activated by foot pedal.
- Portable and lightweight.

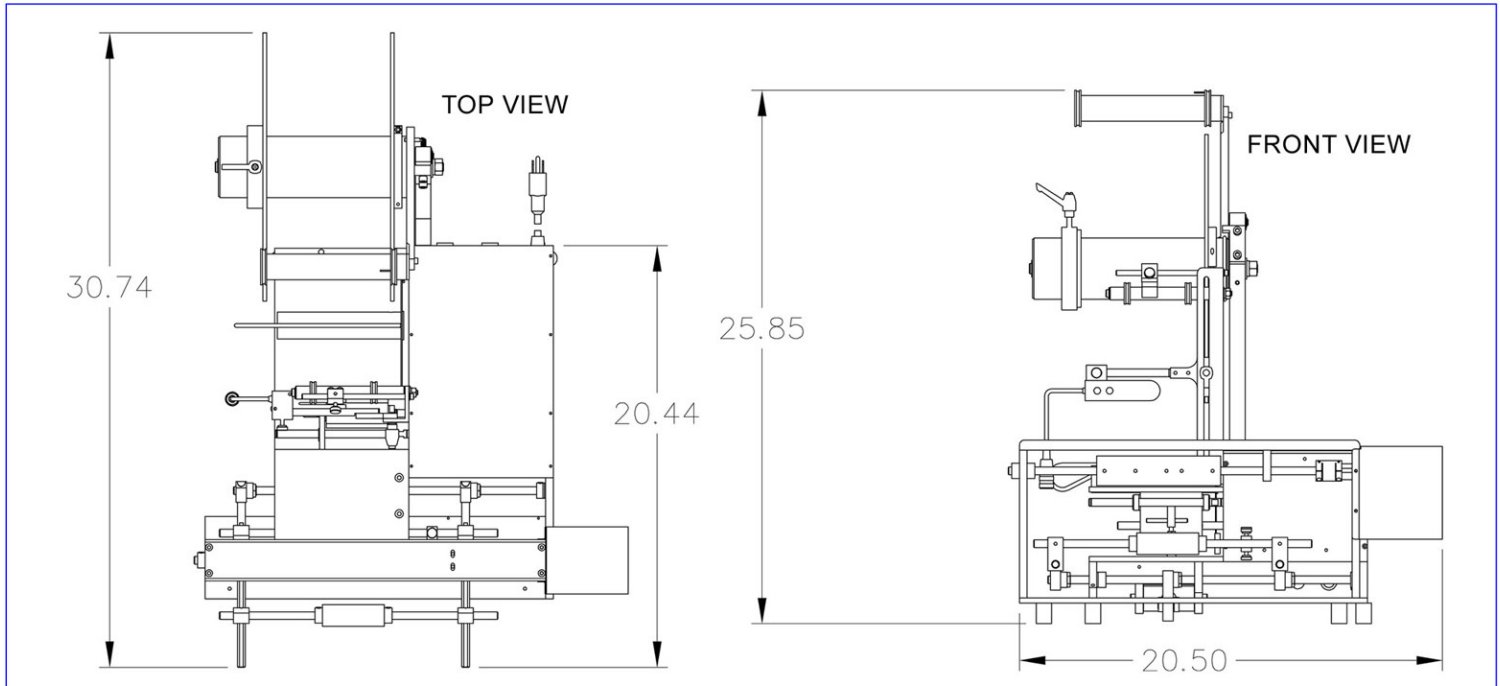

EQUIPMENT SPECIFICATIONS:

DIMENSIONS: (overall)

Width: 20.5 in. / 52.1 cm

Length: 30.74 in. / 78.1 cm

Height: 25.85 in. / 65.7 cm

WEIGHT:

42 lbs / 19 kg

ELECTRIC:

115 VAC / 60HZ / 1.5AMP (max.)

AIR:

50 PSIG (min.) to 90 PSIG (max.) / 2 CFM

LABEL SPECIFICATIONS:

Standard 5" Web Width / 10" O.D. Roll with 3" Core
Pressure sensitive / Die Cut

SHIPPING WEIGHT:

52 lbs. / 24 kg

SHIPPING CRATE DIMENSIONS: (approx.)

Width: 24 in. / 61 cm

Length: 24 in. / 61 cm

Height: 18 in. / 46 cm

OPTIONS AVAILABLE

- Manual activator for label application
- Model 310 Hot Stamp Imprinter
- Photoelectric label sensor
- Gallon-sized modification
- Wide label kits
- Spare parts kit



DIVISION OF BOOTH MANUFACTURING COMPANY

3101 Industrial Avenue Two, Fort Pierce, Florida 34946
Toll Free 800-634-5376 • 772-465-4441 • Fax 772-465-5177
www.autolabe.com • e-mail: info@autolabe.com