

Model RLC4150

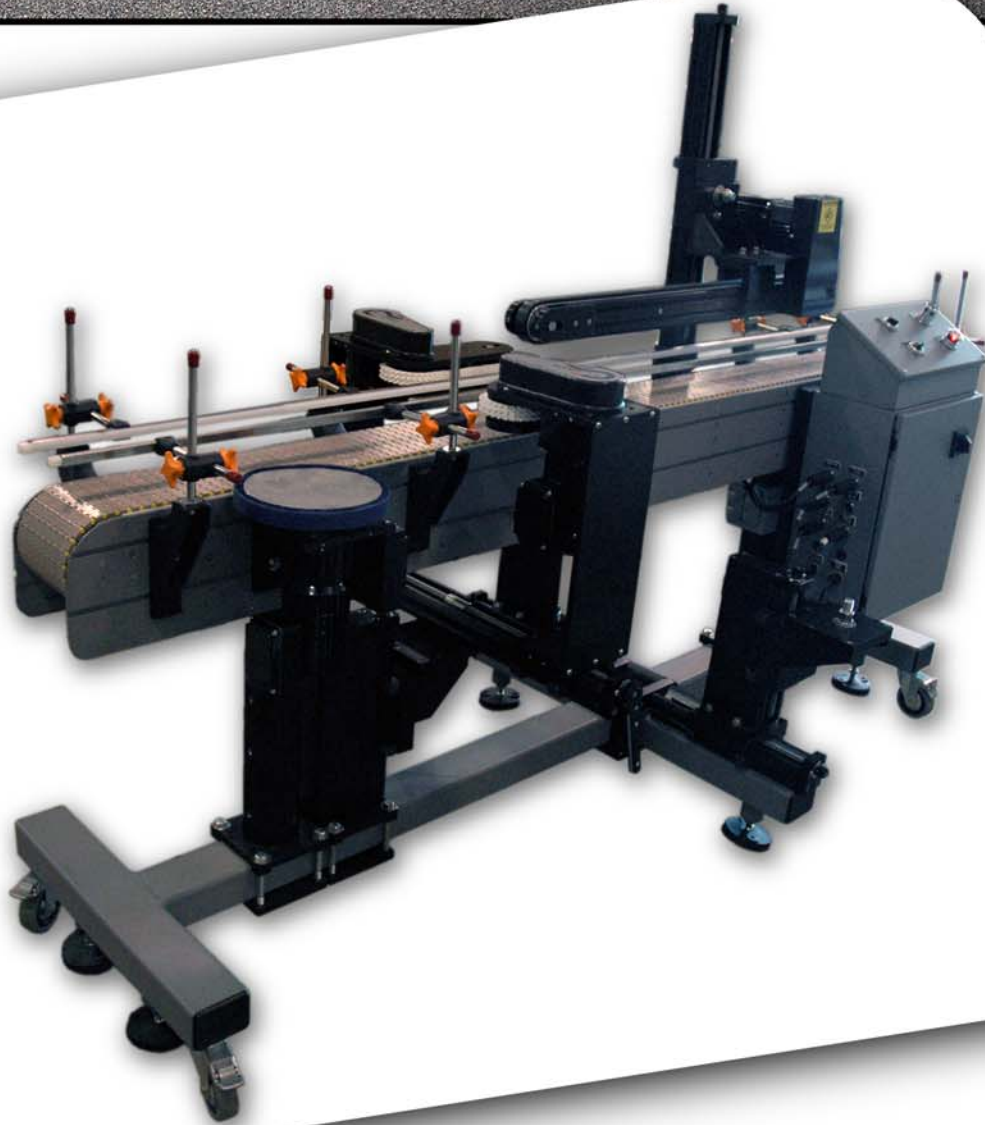

Cost Effective Front Back Conveyor System



System Features

- Mattop Table Top Chain
- 1" Wide x 48" Long Top Hold Down
- Allen Bradley Variable Speed AC Drives
- 1/2 HP AC Motor (Conveyor)
- 3/8 HP AC Gear-Motor (THD)
- Stainless Steel Fasteners
- Sealed for Life Bearings
- Support Base with Double Locking Casters and Leveling Feet
- (2) Integrated Upright with Horizontal Kit
- Conveyor Height Adjustment (+/- 3")
- Fully Adjustable Guide Railing
- Timing Belt Drive
- Powder Coated / Anodized Aluminum and Powder Coated Steel Construction

System Options

- Centerline Adjusting Opposing Belt Aligner (shown above)
- Metering Wheel (shown above)
- Timing Screw
- 3 Panel Gate Label Applicators
- Wrap Station
- Powered or Passive Foam Rollers
- Wipe Down Brushes
- Sensor / Reflector Mount
- Scanner Mounting Adapter Plates
- Scanner Control Mounting Plates
- Centralized Control Box (shown above)



6496 State Route 45
Lisbon, Ohio 44432

(330) 424-1525
fax (330) 424-0763

info@rlcraig.com
www.rlcraig.com

Model RLC4150

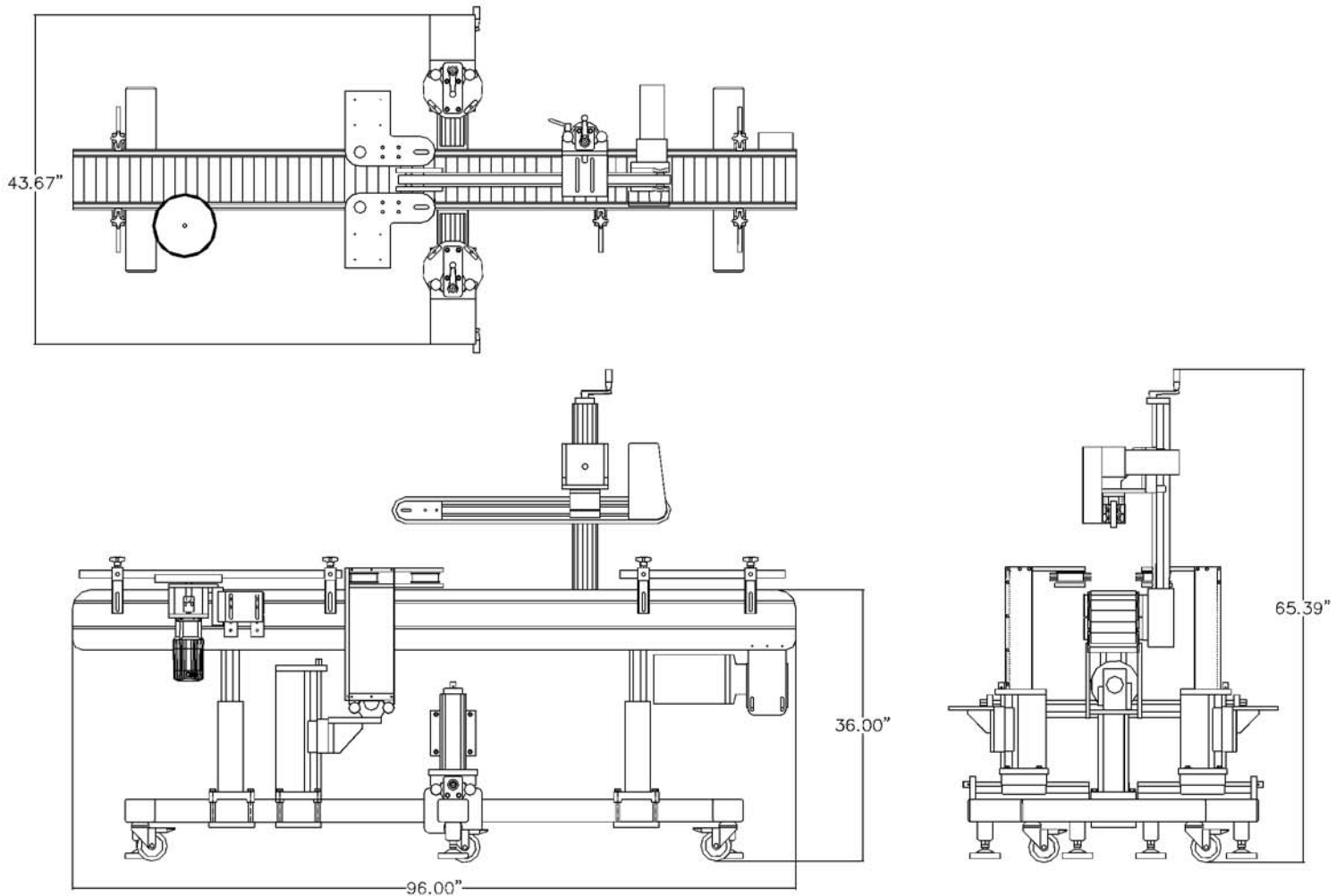

Electrical Requirements

- 120 VAC / 6 Amp
- * Additional voltages available upon request

Conveyor Widths

- 3" - 12" (3" Increments)
- * Custom widths available upon request

Conveyor Lengths

- 6ft, 8ft, 10ft, 12ft
- * Custom lengths available upon request

Approximate Dimensions

- Length - 96"
- Width - 43.67"
- Height - 65.39"
- * Will vary dependant upon conveyor size

Approximate Weight

- 925 Pounds
- * Will vary dependant upon conveyor size

Distributed By:



6496 State Route 45
Lisbon, Ohio 44432

(330) 424-1525
fax (330) 424-0763

info@rlcraig.com
www.rlcraig.com