

# Model RLC1500



## Wrap System - Round Product Labeling



### System Features

- Mattop Table Top Chain
- Integrated Wrap Station (2" - 8" width, 12" - 24" length)
- Padded Back-up Plate
- Variable Speed DC Drives
- 1/2 HP DC Motor and Gearbox (Conveyor)
- 1/4 HP DC Gear-motor (Wrap Station)
- Stainless Steel Fasteners
- Sealed for Life Bearings
- Support Base with Double Locking Casters and Leveling Feet
- Integrated 54" Upright with Horizontal Kit
- Height Adjustment (+/- 3")
- Fully Adjustable Guide Railing
- Timing Belt Drive
- Powder Coated/Anodized Aluminum and Powder Coated Steel Construction

### System Options

- Centralized Control Panel (shown above)
- Metering Wheel
- Timing Screw
- AC Drives
- Product Sensor Mount
- 4 Plug Receptacle Box
- Remote Emergency Stop



6496 State Route 45  
Lisbon, Ohio 44432

(330) 424-1525  
fax (330) 424-0763

info@rlcraig.com  
www.rlcraig.com

# Model RLC1500

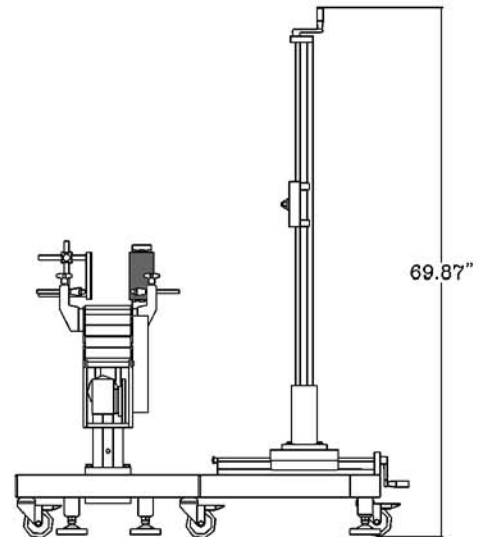
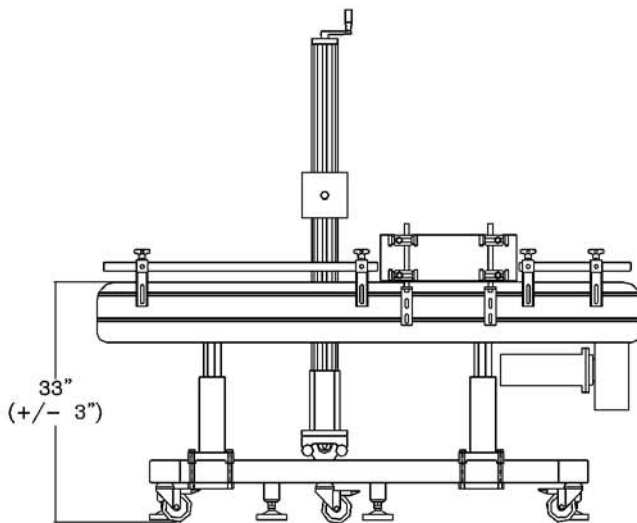
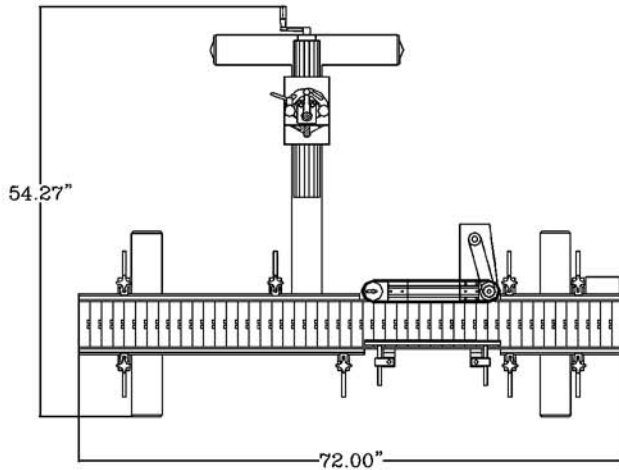

## Electrical Requirements

- 120 VAC / 6 Amp
- \* *Additional voltages available upon request*

## Conveyor Widths

- 3" - 12" (3" Increments)
- \* *Custom widths available upon request*

## Conveyor Lengths

- 4ft, 6ft, 8ft, 10ft, 12ft
- \* *Custom lengths available upon request*

## Approximate Dimensions

- *Dependent on Conveyor Length & Width*

## Approximate Weight

- *Dependent on Conveyor Length & Width*

*Distributed By:*



6496 State Route 45  
Lisbon, Ohio 44432

(330) 424-1525  
fax (330) 424-0763

info@rlcraig.com  
www.rlcraig.com