

Model RLC1000



Mattop Chain Conveyor System



(Shown with Optional Product Fixtures)

System Features

- Stainless Steel Fasteners
- Sealed for Life Bearings
- Variable Speed DC Motor
- 1/4 HP DC Gear-motor
- Rexnord Mattop Chain
- Support Legs with Leveling Feet
- Height Adjustment (+/- 3")
- Fully Adjustable Guide Railing
- Timing Belt Drive
- Powder Coated/Anodized Aluminum and Powder Coated Steel Construction

System Options

- Variable Speed AC Drive (Digital Display)
- Double Locking Casters
- Support Base with Double Locking Casters and Leveling Feet
- Remote Emergency Stop
- Sensor - Reflector Mount
- Scanner Mounting Adapter Plates
- Scanner Control Mounting Plates
- Ink Jet Mounting Adapter Plates



6496 State Route 45
Lisbon, Ohio 44432

(330) 424-1525
fax (330) 424-0763

info@rlcraig.com
www.rlcraig.com

Model RLC1000

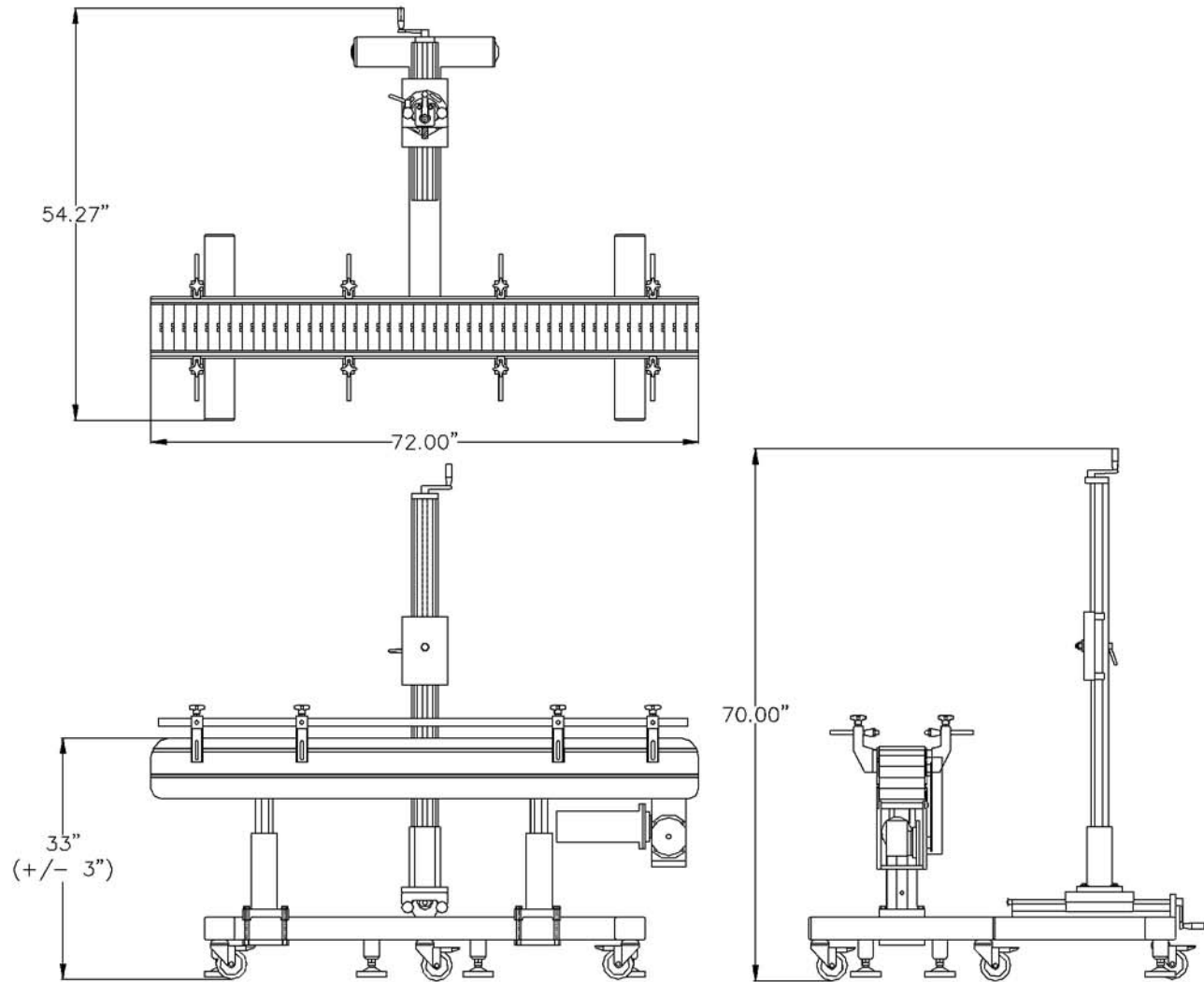

Electrical Requirements

- 120 VAC / 6 Amp
- * *Additional voltages available upon request*

Conveyor Widths

- 3" - 12" (3" Increments)
- * *Custom widths available upon request*

Conveyor Lengths

- 4ft, 6ft, 8ft, 10ft, 12ft
- * *Custom lengths available upon request*

Approximate Dimensions

- *Dependent on Conveyor Length & Width*

Approximate Weight

- *Dependent on Conveyor Length & Width*

Distributed By:



6496 State Route 45
Lisbon, Ohio 44432

(330) 424-1525
fax (330) 424-0763

info@rlcraig.com
www.rlcraig.com