

3115

 LABEL-AIRE®

Model 3115 Wipe-On

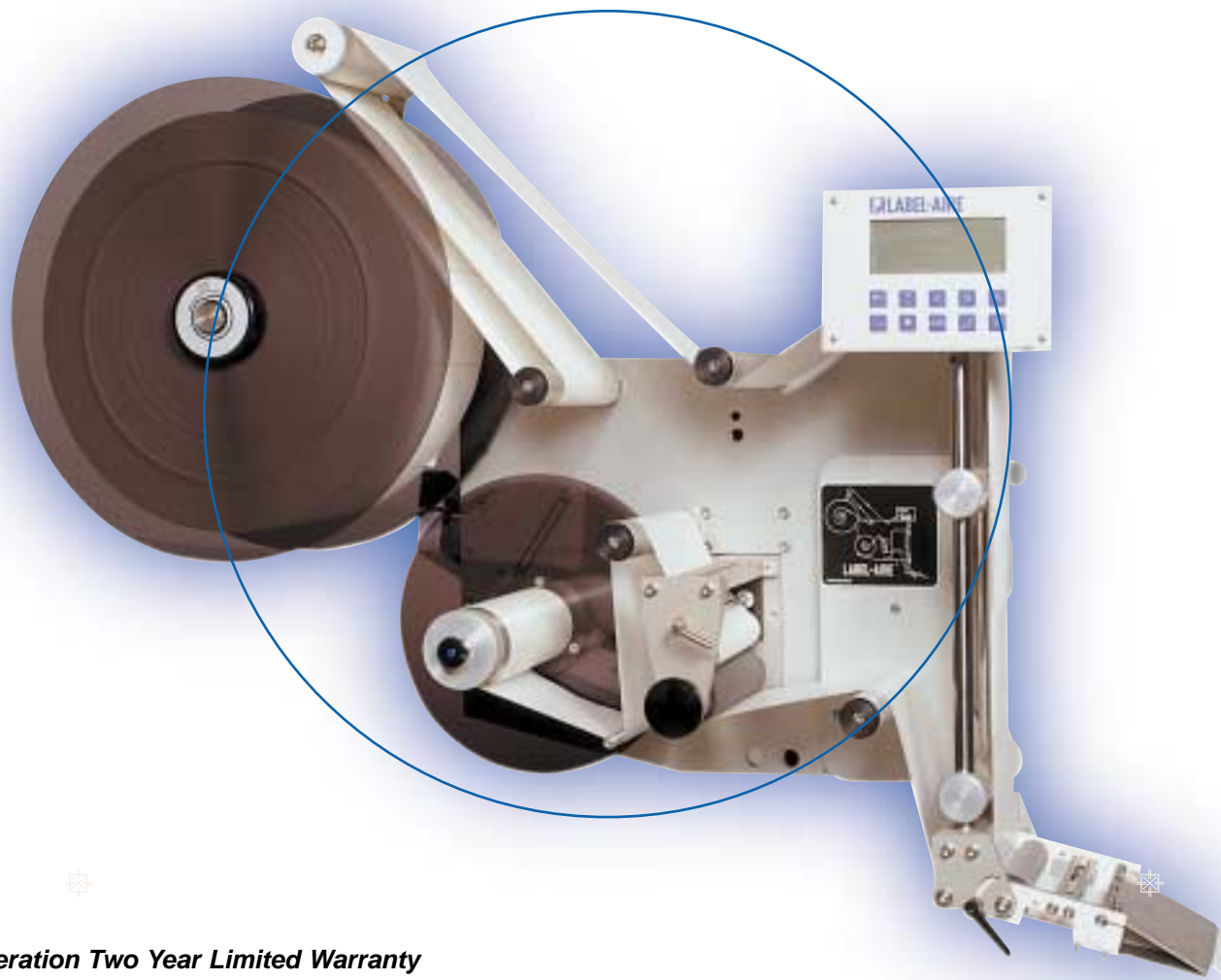

New Generation Two Year Limited Warranty

LABEL-AIRE®... LABELING SOLUTIONS THAT APPLY™

precision

3115

! LABEL-AIRE®

Model 3115 Wipe-On

The Label-Aire® Model 3115 represents the ultimate in high-speed wipe-on pressure-sensitive labeling technology.

The Model 3115 Wipe-On labeler is simply the most advanced labeler on the market with its intelligent controller, impressive speeds, and high accuracy. The user-friendly 3115 is loaded with advanced features: **Automatic label setup**, **Automatic Speed Following (ASF)**, **Zero Downtime Labeling**, and a large **R3 digital display** that is Rotateable, Remoteable, and very Readable. With five onboard **user-selectable languages**, **domestic or CE** (European) configurations, and **standard/metric unit display**, the 3115 can handle almost any PS labeling application on the planet.

Built for speed, accuracy, and ease of use, the 3115 delivers. Its advanced **ASF with product surface profiling** ensures wrinkle-free labeling on even the most difficult product shapes and label materials. Thanks to the 3115's **advanced product/label queuing and missing label compensation**, problems caused by missing labels on a roll, such as unlabeled product, double labeled product, or missing lot and expiration codes, are virtually eliminated.

- **Automatic setup** with multiple programmable label pages for easy changeovers to different label sizes.
- **R3 digital display** with five languages (English, French, German, Italian, Spanish) and detailed alarm messages.
- Advanced **Automatic Speed Following (ASF)** means the labels are always accurately applied even **through extreme changes in product speed**.
- **Quick-action collapsible rewind** for easy removal of scrap liner.
- Optional **smart powered rewind** for improved label accuracy and **dynamic web tension control**.
- Wipe-on applicator **easily adapts** to air-blow or tamp-blow use.

! LABEL-AIRE®

550 Burning Tree Road
Fullerton, CA 92833 USA
v: 714-441-0700 f: 714-526-0300

Sjaellandsvej 27 A
Hobro, DK-9500 Denmark
v: 45 96 57 00 63 f: 45 96 57 00 64

e: info@label-aire.com
i: www.label-aire.com

Distributed by:

IMPAXX
THE COMPLETE PACKAGE
MACHINE SYSTEMS

© 2002 Impaxx Machine Systems.
All Rights Reserved. Printed in U.S.A.

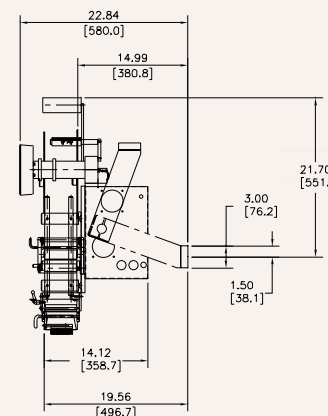
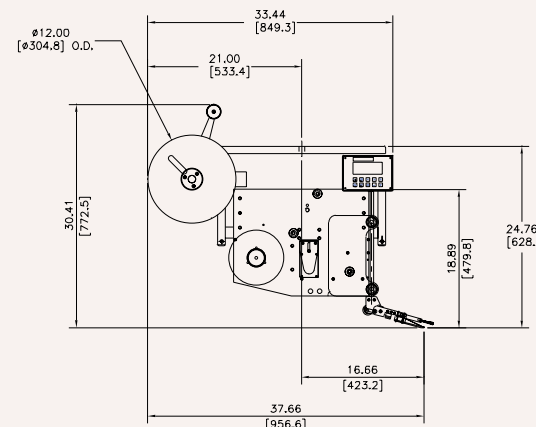

S P E C S

Dimensions:

Height: 30.5" (775 mm)
Length: 33.5" (850 mm)
Width: 22.9" (582 mm)

Weight:

145 lbs. (65.7 kg)

Standard Label Dimensions:

Max. Web Width: 7.13" (181 mm)
Min. Web Width: .63" (16 mm)
Min. Label Length: .5" (13 mm)

Label Packaging:

12" (305 mm) O.D. rolls std. on 3"
(76 mm) I.D. cores
Up to 16" (406 mm) rolls with
powered rewind

Dispense Speed:

Up to 1500" (3810 cm) of web per
minute (standard)
Up to 2000" (5080 cm) of web per
minute with optional 16"
(406 mm) unwind

Label Placement Accuracy:

Up to +/- 1/64" (.4 mm)

Electrical:

115 Volts AC 60 Hz 3 Amps.
220 Volts AC 50 Hz optional

Air (as needed):

2 cfm at 60 psi to 90 psi when
imprinter is used

Options:

16" (406 mm) non-powered
unwind
Smart 10" (254 mm) powered
rewind
6" (152 mm) label core adapter
Encoder kit for Automatic Speed
Following,
Strobe signals for "low label" and
"out of labels"

*Shown with optional 16" (406 mm)
non-powered unwind and powered
rewind.*

Label-Aire also provides a full range of
rotary & inline systems, label applicators,
printer applicators, and custom systems
to meet your toughest labeling requirements.