

3114

 LABEL-AIRE®

Model 3114 Tamp-Blow

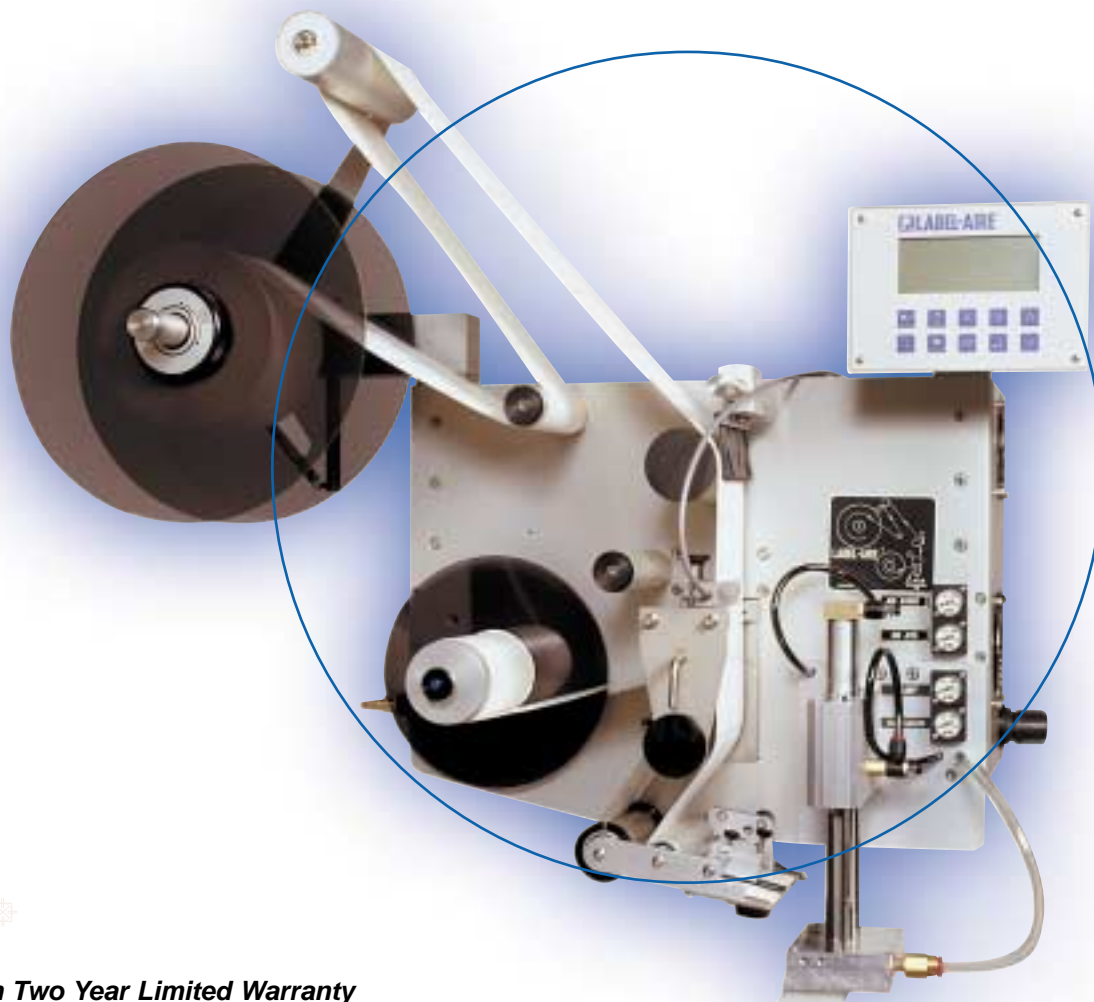

*New Generation Two Year Limited Warranty*

LABEL-AIRE®... LABELING SOLUTIONS THAT APPLY™

precision

# 3114

## Model 3114 Tamp-Blow

The Label-Aire® Model 3114 represents the ultimate in high-speed tamp-blow pressure-sensitive labeling technology.

The Model 3114 Tamp-Blow labeler is simply the most advanced labeler on the market with its intelligent controller, impressive speeds, and high accuracy. The user-friendly 3114 is loaded with advanced features: **Automatic label setup, Automatic Speed Following (ASF), Zero Downtime Labeling**, and a **large R3 digital display** that is Rotateable, Remoteable, and very Readable. With five onboard **user-selectable languages, domestic or CE** (European) configurations, and **standard/metric unit display**, the 3114 can handle almost any PS labeling application on the planet.

Built for speed, accuracy, and ease of use, the 3114 delivers. The advanced **ASF with product queuing** means the labels are always accurately applied through extreme changes in product speed. Thanks to the 3114's **advanced label queuing and missing label compensation**, problems caused by missing labels on a roll, such as unlabeled product, double labeled product, or missing lot and expiration codes, are virtually eliminated.

- **Automatic setup** with multiple programmable label pages for easy changeovers to different label sizes.
- **R3 digital display** with five languages (English, French, German, Italian, Spanish) and detailed alarm messages.
- Advanced **Automatic Speed Following (ASF)** means the labels are always accurately applied even **through extreme changes in product speed**.
- **Quick-action collapsible rewind** for easy removal of scrap liner.
- Optional **smart powered rewind** for improved label accuracy and **dynamic web tension control**.
- Tamp-blow applicator **easily adapts** to air-blow or wipe-on use.

550 Burning Tree Road  
Fullerton, CA 92833 USA  
v: 714-441-0700 f: 714-526-0300

Sjaellandsvej 27 A  
Hobro, DK-9500 Denmark  
v: 45 96 57 00 63 f: 45 96 57 00 64

e: info@label-aire.com  
i: www.label-aire.com

Distributed by:

© 2002 Impaxx Machine Systems.  
All Rights Reserved. Printed in U.S.A.

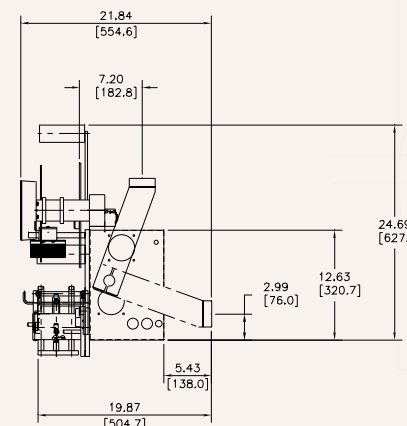
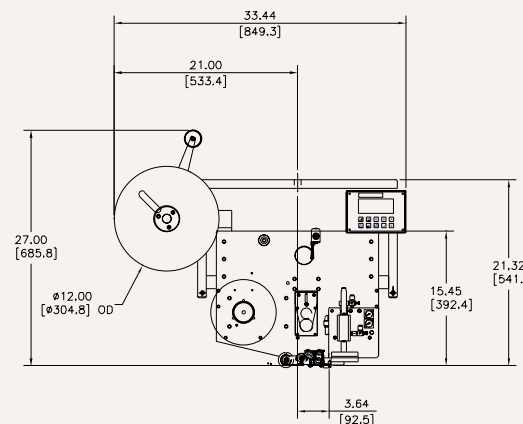

## S P E C S

### Dimensions:

Height: 27" (686 mm)  
Length: 33.5" (850 mm)  
Width: 21.9" (556 mm)

### Weight:

140 lbs. (63.5 kg)

### Standard Label Dimensions:

Max. Web Width: 4.13" (105 mm)  
Optional 7.13" (181 mm) Label Width  
Min. Web Width: .63" (16 mm)  
Min. Label Length .38" (10 mm)

### Label Packaging:

12" (305 mm) O.D. rolls std. on 3" (76 mm) I.D. cores  
Up to 16" (406 mm) rolls with optional 16" (406 mm) unwind

### Dispense Speed:

Up to 1500" (3810 cm) of web per minute (standard)  
Up to 2000" (5080 cm) of web per minute with powered rewind

### Label Placement Accuracy:

+/- 1/32" (.8 mm)

### Electrical:

115 Volts AC 60 Hz 3 Amps.  
220 Volts AC 50 Hz optional

### Air:

4 cfm at 90 psi to 110 psi for most applications

### Options:

16" (406 mm) non-powered unwind  
Smart 10" (254 mm) powered rewind  
6" (152 mm) label core adapter  
Encoder kit for Automatic Speed Following  
Strobe signals for "low label" and "out of labels"

Label-Aire also provides a full range of rotary & inline systems, label applicators, printer applicators, and custom systems to meet your toughest labeling requirements.