

3111

 LABEL-AIRE®

Model 3111 Air-Blow

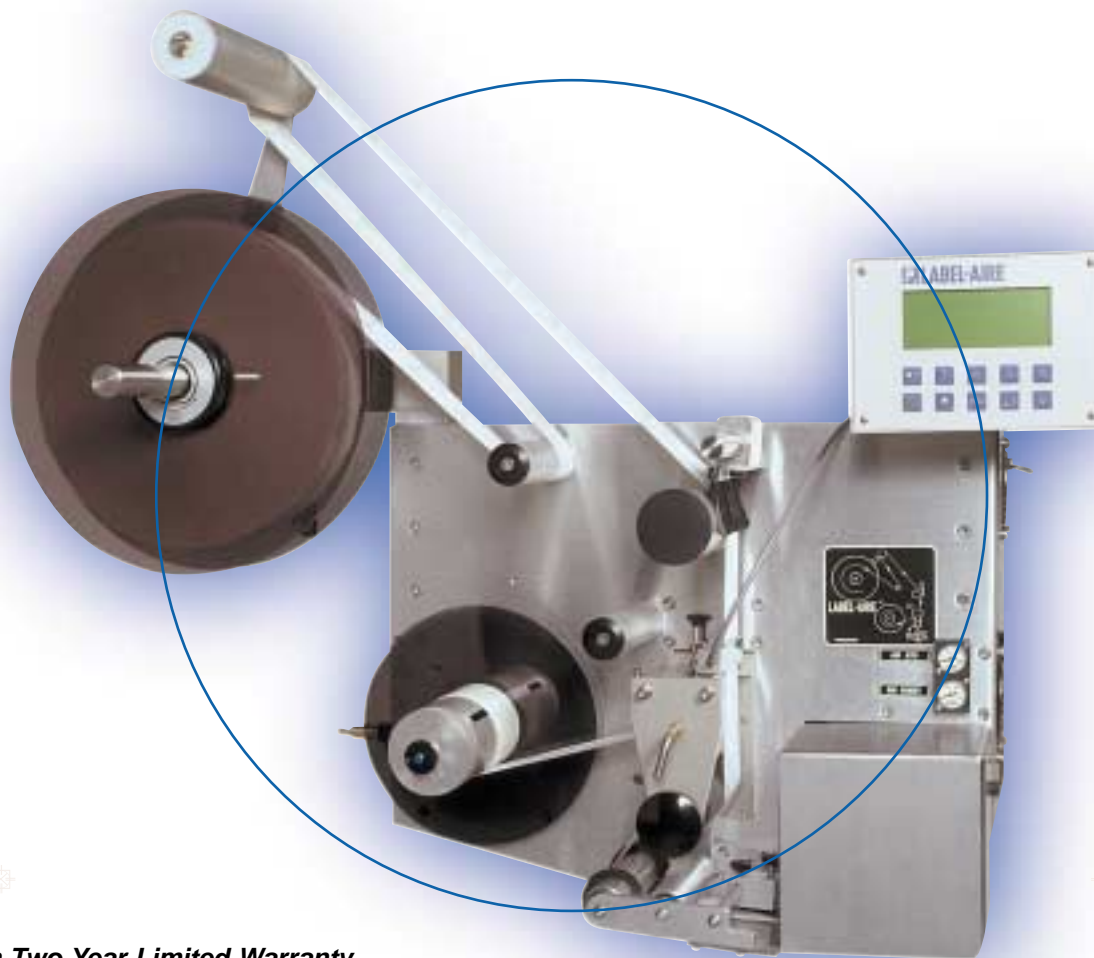

New Generation Two Year Limited Warranty

LABEL-AIRE®... LABELING SOLUTIONS THAT APPLY™

precision

3111

Model 3111 Air-Blow

The Label-Aire® Model 3111 represents the ultimate in high-speed air-blow pressure-sensitive labeling technology.

The Model 3111 Air-Blow labeler is simply the most advanced labeler on the market with its intelligent controller, impressive speeds, and high accuracy. The user-friendly 3111 is loaded with advanced features: **Automatic label setup**, **Automatic Speed Following (ASF)**, **Zero Downtime Labeling**, and a large **R3 digital display** that is Rotateable, Remoteable, and very Readable. With five onboard **user-selectable languages**, **domestic or CE** (European) configurations, and **standard/metric unit display**, the 3111 can handle almost any PS labeling application on the planet.

Built for speed, accuracy, and ease of use, the 3111 delivers. The advanced **ASF with product queuing** means the labels are always accurately applied through extreme changes in product speed. Thanks to the 3111's **advanced label queuing and missing label compensation**, problems caused by missing labels on a roll, such as unlabeled product, double labeled product, or missing lot and expiration codes, are virtually eliminated.

- **Automatic setup** with multiple programmable label pages for easy changeovers to different label sizes.
- **R3 digital display** with five languages (English, French, German, Italian, Spanish) and detailed alarm messages.
- Advanced **Automatic Speed Following (ASF)** means the labels are always accurately applied even **through extreme changes in product speed**.
- **Quick-action collapsible rewind** for easy removal of scrap liner.
- Optional **smart powered rewind** for improved label accuracy and **dynamic web tension control**.
- Air-blow applicator **easily adapts** to tamp-blow or wipe-on use.

550 Burning Tree Road
Fullerton, CA 92833 USA
v: 714-441-0700 f: 714-526-0300

Sjaellandsvej 27 A
Hobro, DK-9500 Denmark
v: 45 96 57 00 63 f: 45 96 57 00 64

e: info@label-aire.com
i: www.label-aire.com

Distributed by:

© 2002 Impaxx Machine Systems.
All Rights Reserved. Printed in U.S.A.

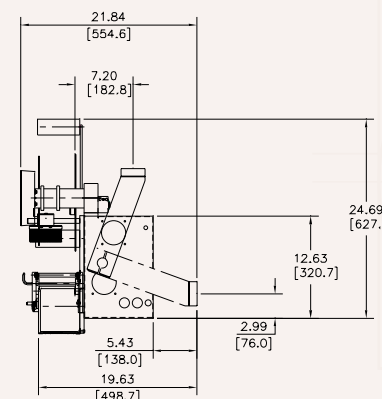
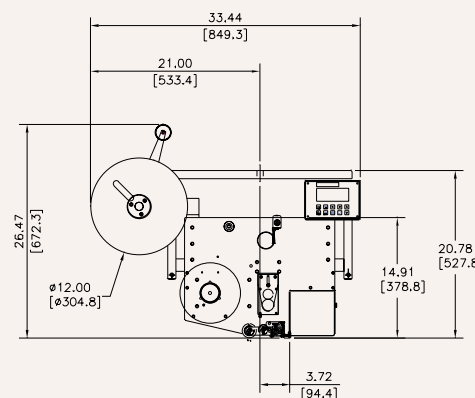

S P E C S

Dimensions:

Height: 26.5" (673 mm)
Length: 33.5" (850 mm)
Width: 21.9" (556 mm)

Weight:

140 lbs. (63.5 kg)

Standard Label Dimensions:

Max. Web Width: 4.13" (105 mm)
Min. Web Width: .88" (22 mm)
Min. Label Length .75" (19 mm)

Label Packaging:

12" (305 mm) O.D. rolls std. on
3" (76 mm) I.D. cores
Up to 16" (406 mm) rolls with
powered rewind

Dispense Speed:

Up to 1500" (3810 cm) of web per
minute (standard)
Up to 2000" (5080 cm) of web per
minute with optional 16" (406)
unwind

Label Placement Accuracy:

+/- 1/32" (.8 mm)

Electrical:

115 Volts AC 60 Hz 3 Amps.
220 Volts AC 50 Hz optional

Air:

4 cfm at 90 psi to 110 psi for most
applications

Options:

16" (406 mm) non-powered
unwind
Smart 10" (254 mm) powered
rewind
6" (152 mm) label core adapter
Encoder kit for Automatic Speed
Following
Strobe signals for "low label" and
"out of labels"

Label-Aire also provides a full range of
rotary & inline systems, label applicators,
printer applicators, and custom systems
to meet your toughest labeling requirements.